



A Soft Robot for Surgical Interventions

Team Members: Maxwell Anderson, Sean Dunkelman, Christopher Gonzalez-Millan, Brady King, Isaac Martinez, Bradley Nam, Caitlyn Robinson, Renée Schnettler, William Wang, William Watkins



University of Colorado Boulder, The Paul M. Rady Department of Mechanical Engineering

1 Project Motivation

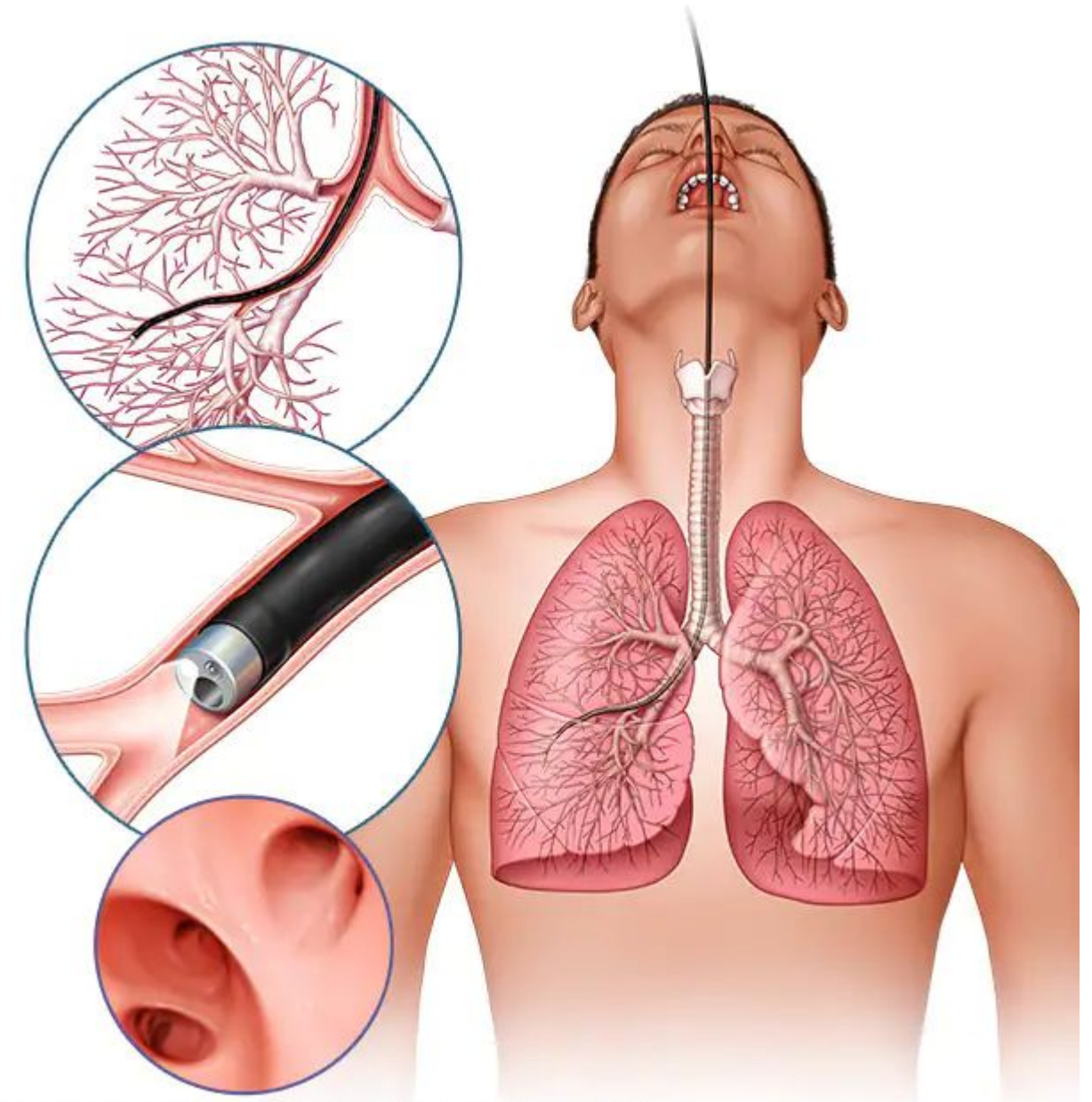

- Lung cancer is the leading cause of cancer-related deaths worldwide
- 13% of all new cancers begin in the lung
- Existing bronchoscopes have limitations in clinical settings

Features to Maximize

Controls — Patient safety — Depth of Biopsy

2 Proposed Solution

Soft Robotics

- Uses Compliant Materials
- Adaptable in unpredictable environments
- Lots of promise in Biomedical applications
- Safer in Robot-Human Interactions
- Sensing and control with these robots are an intriguing and continued point of research

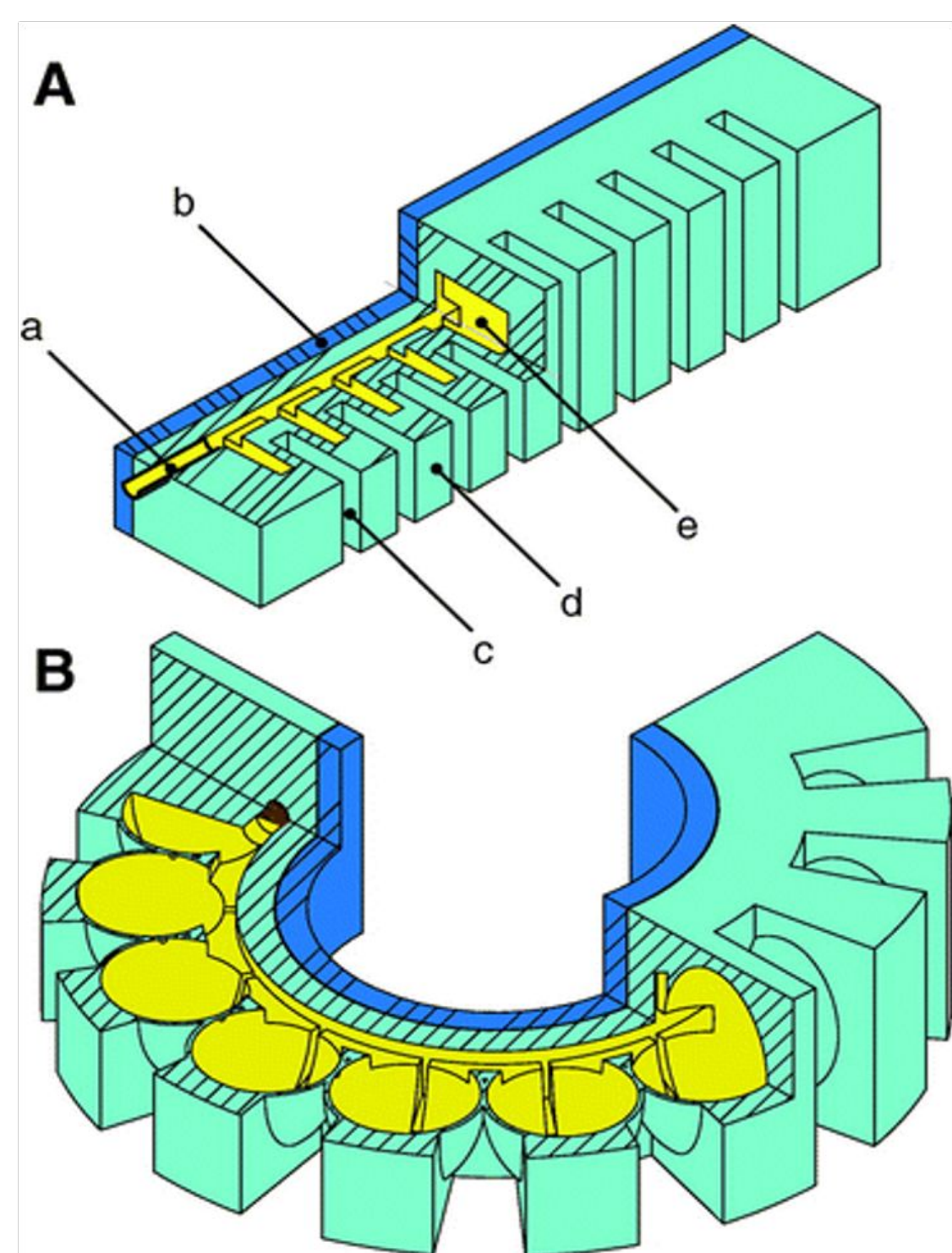

<https://www.liebertpub.com/doi/10.1089/soro.2014.0022>

Fluidic Elastomer Actuators

- Class of Soft Robotic Actuators that utilize positive pressure from a fluid to induce bending

Bubble Design

- Different wall thicknesses to direct robot's actuation

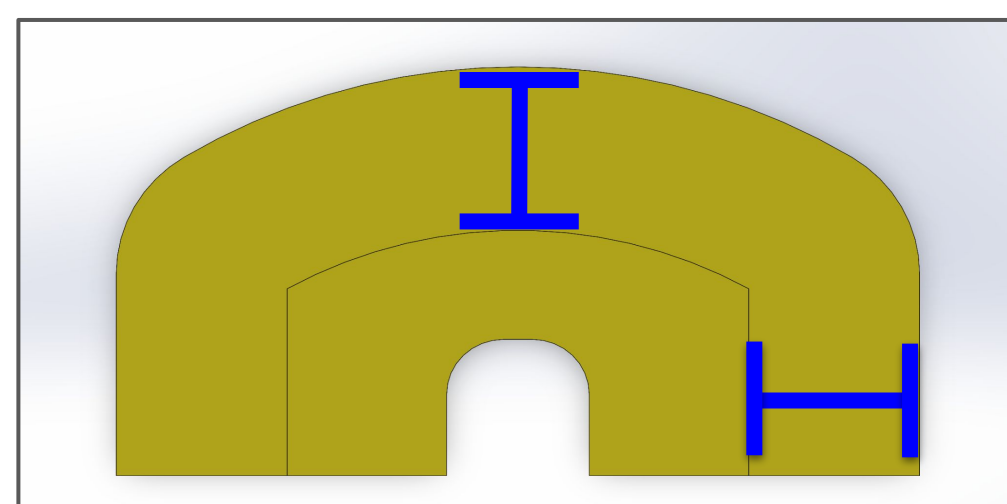

- Cavities for air movement

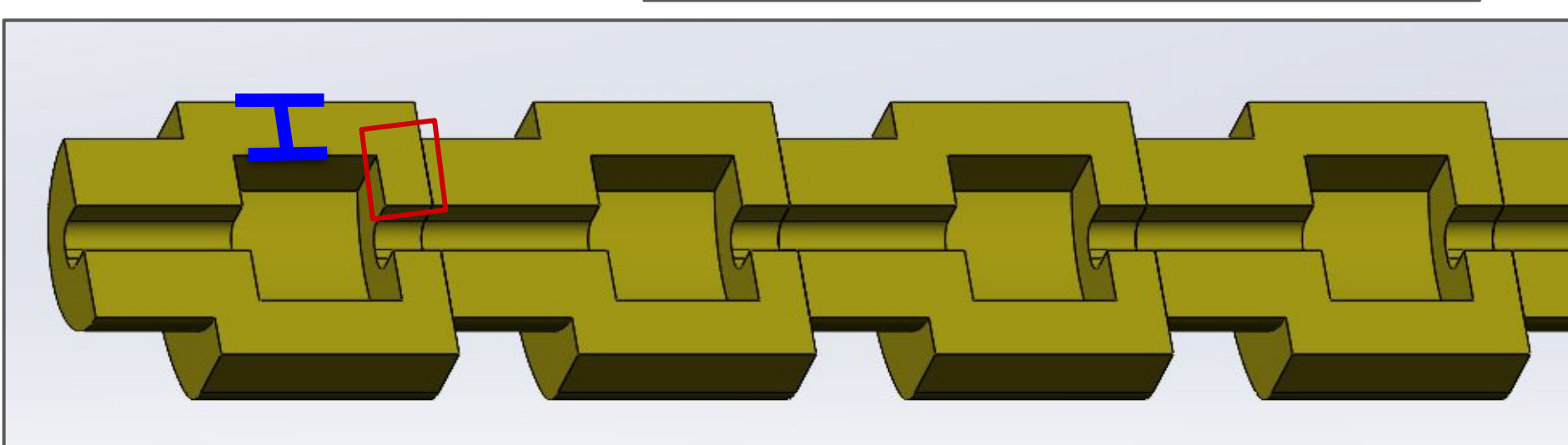

3 Mechanical Design

Iterations

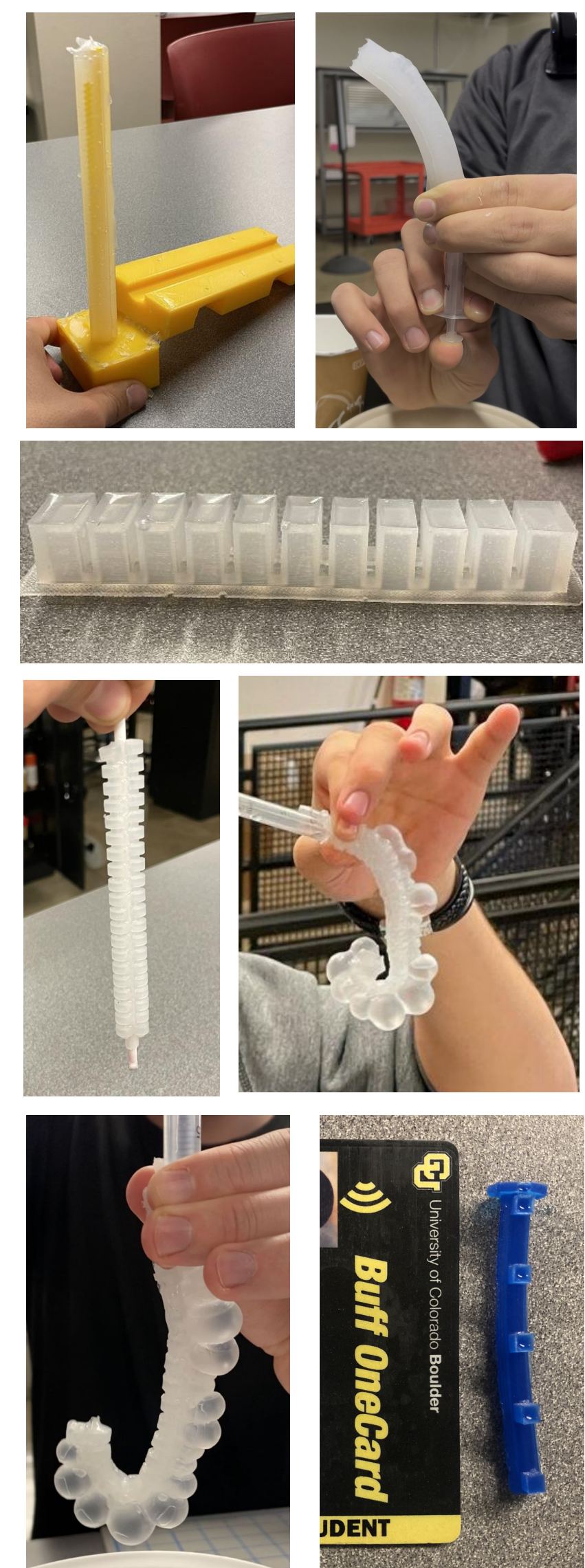

Full length
6 cm

Final diameter
6 mm

Mechanical Design

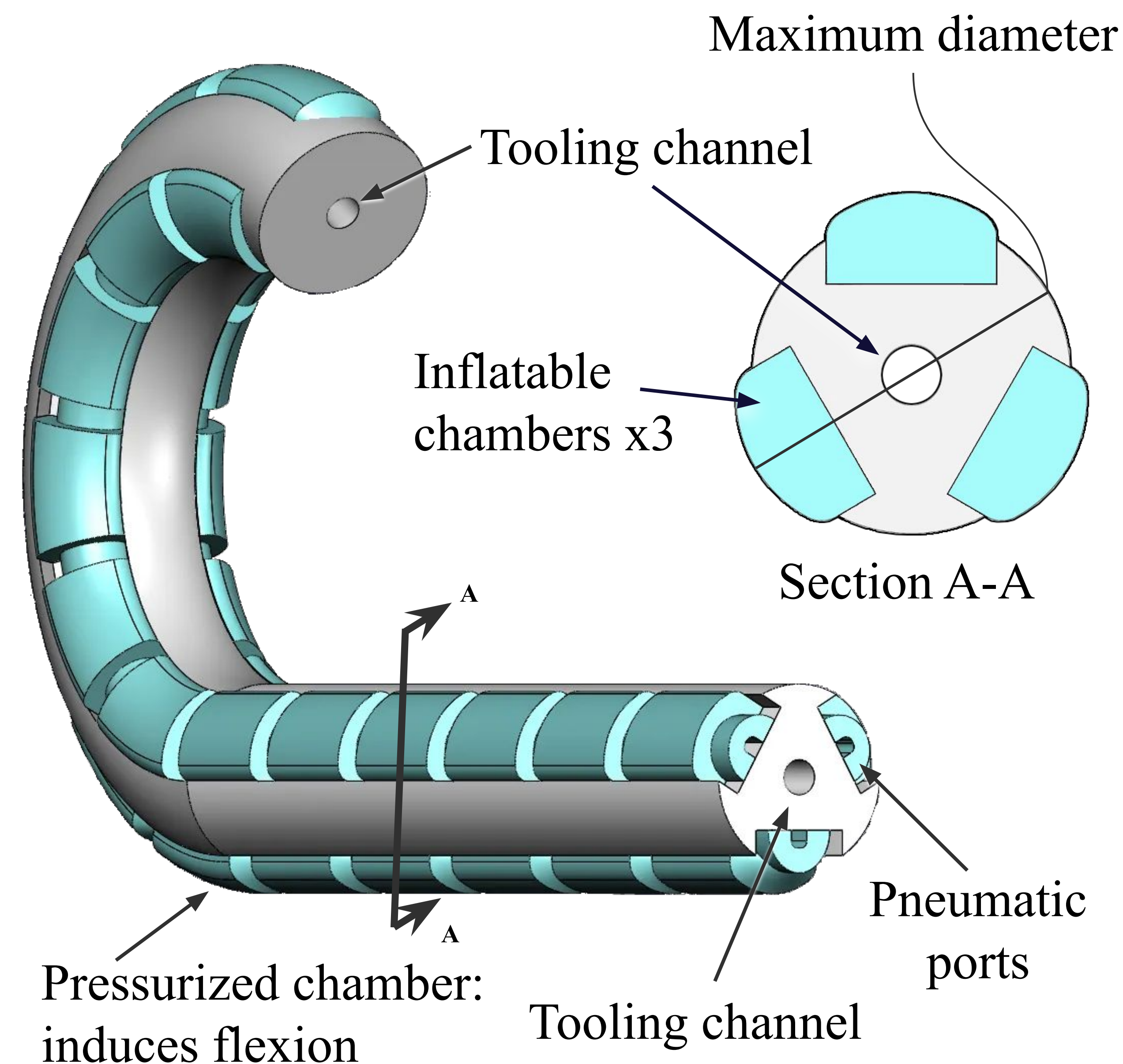

Due to the complexity of computational models for soft robotics, we underwent an iterative design process with **55 iterations** of separate designs and prototypes.

4 Robotic Controls

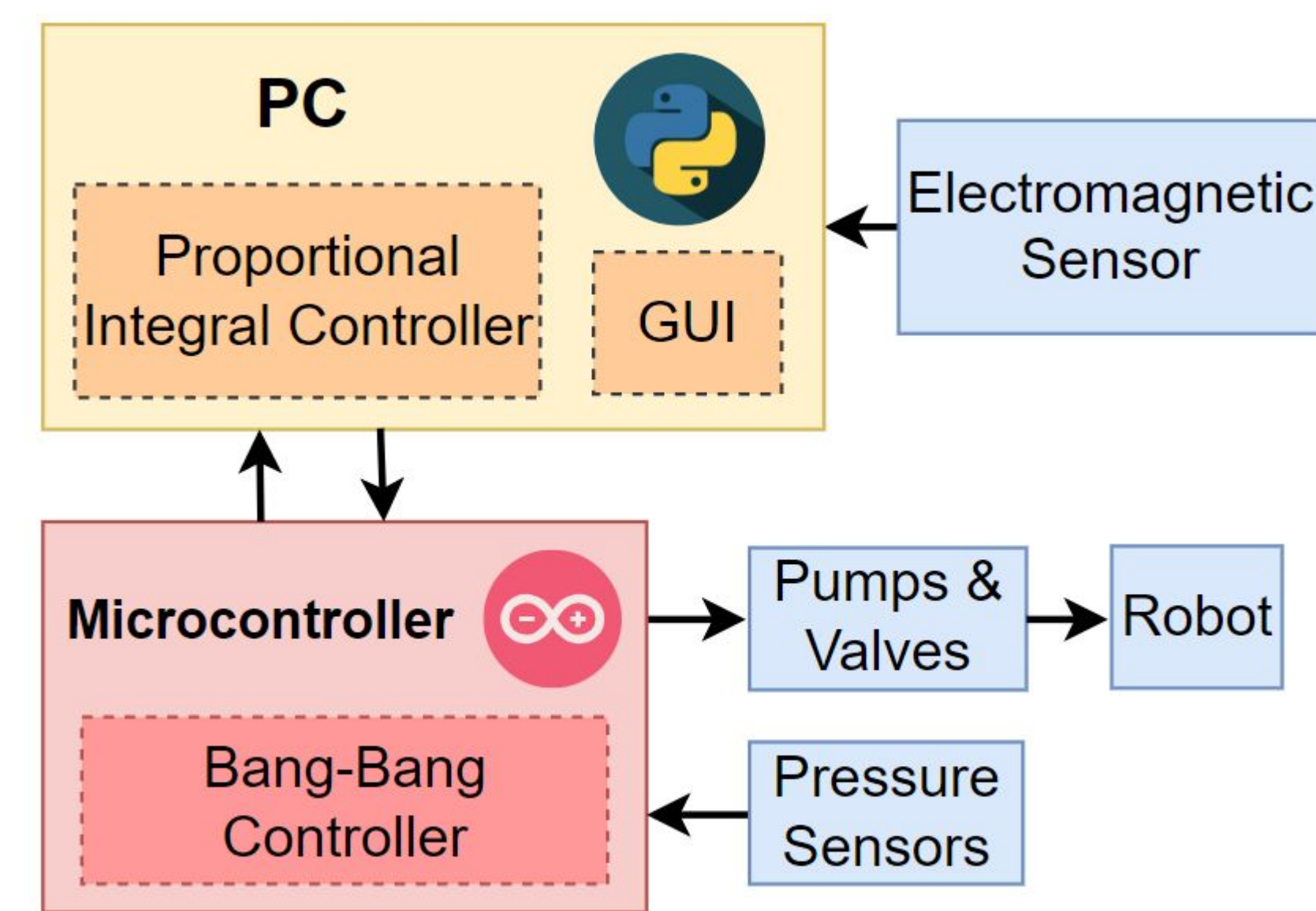

Control System

- Low-level pressure control integrated with our high-level algorithms

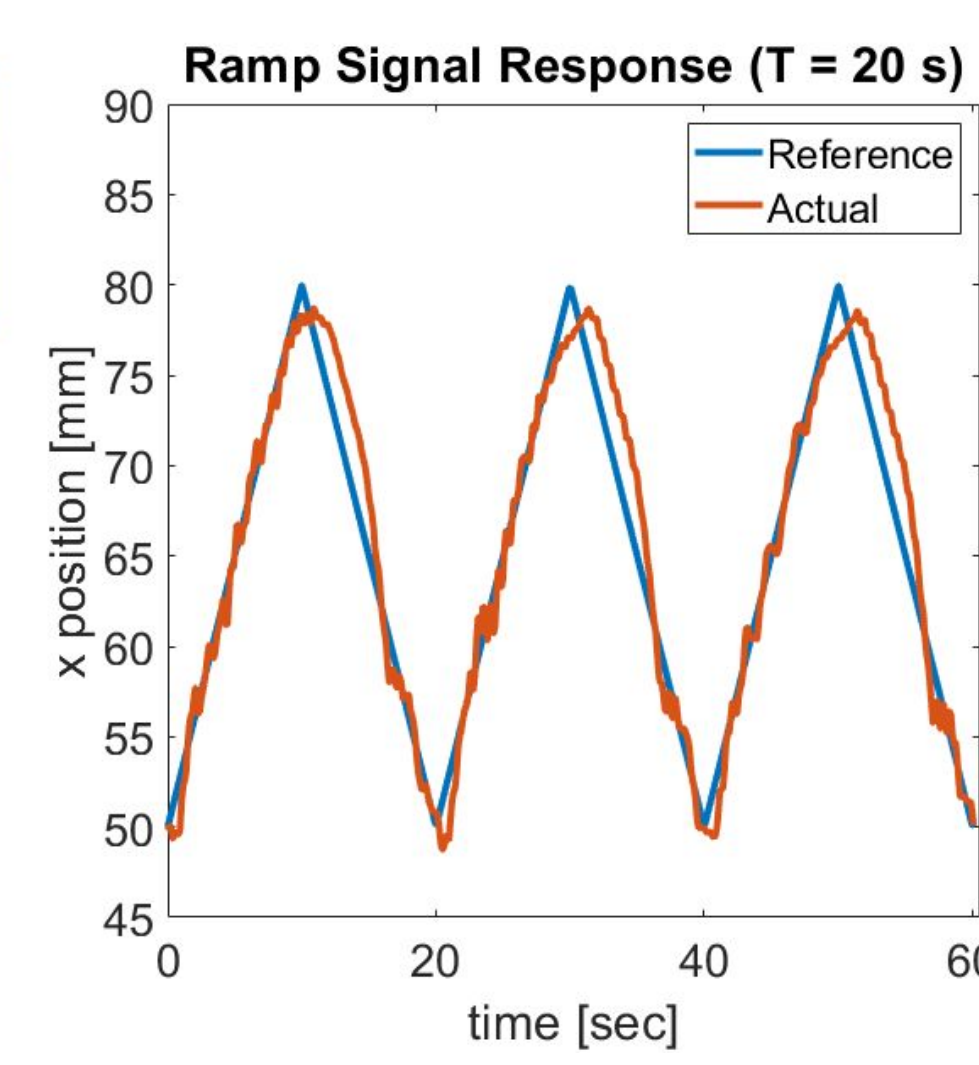

Position Signal Tracking

- One channel robot tracking linear trajectory
- Three channel robot tracking circular trajectory

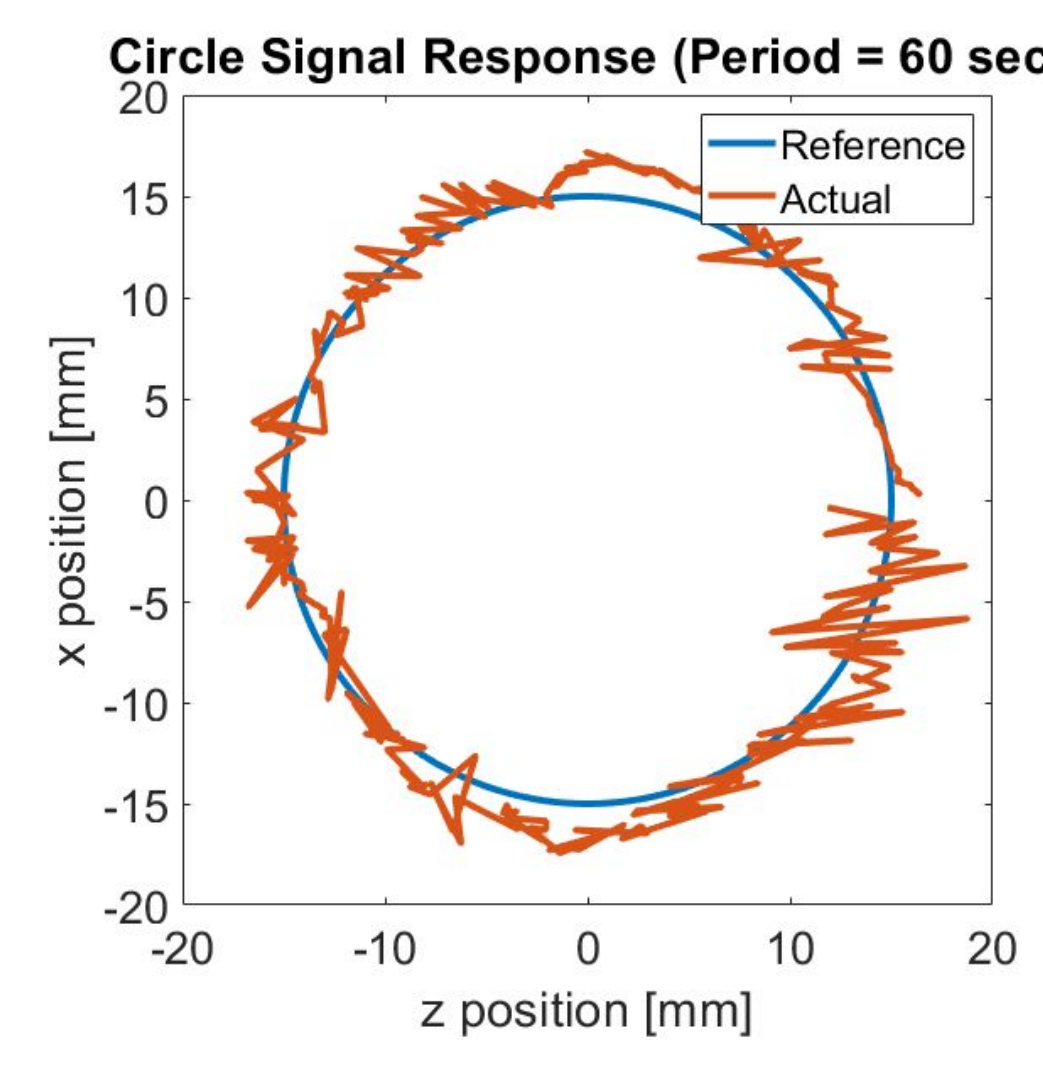

5 Testing

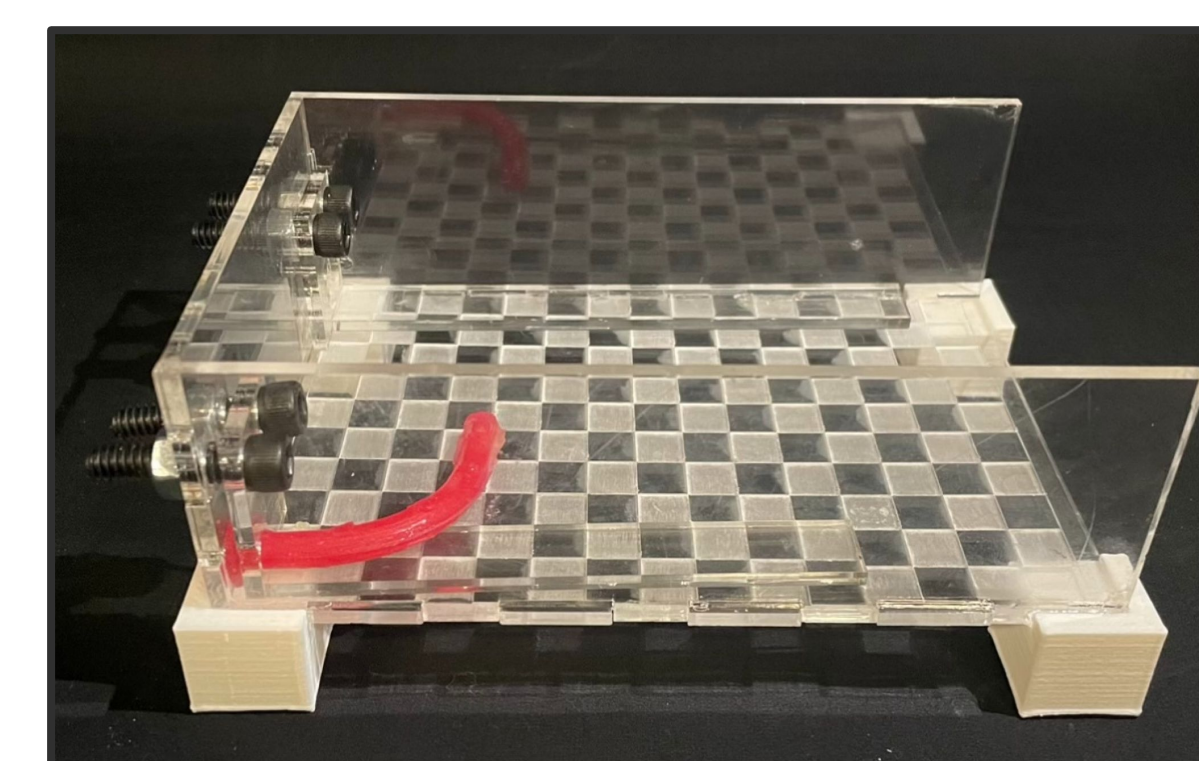

Bending Test Fixture

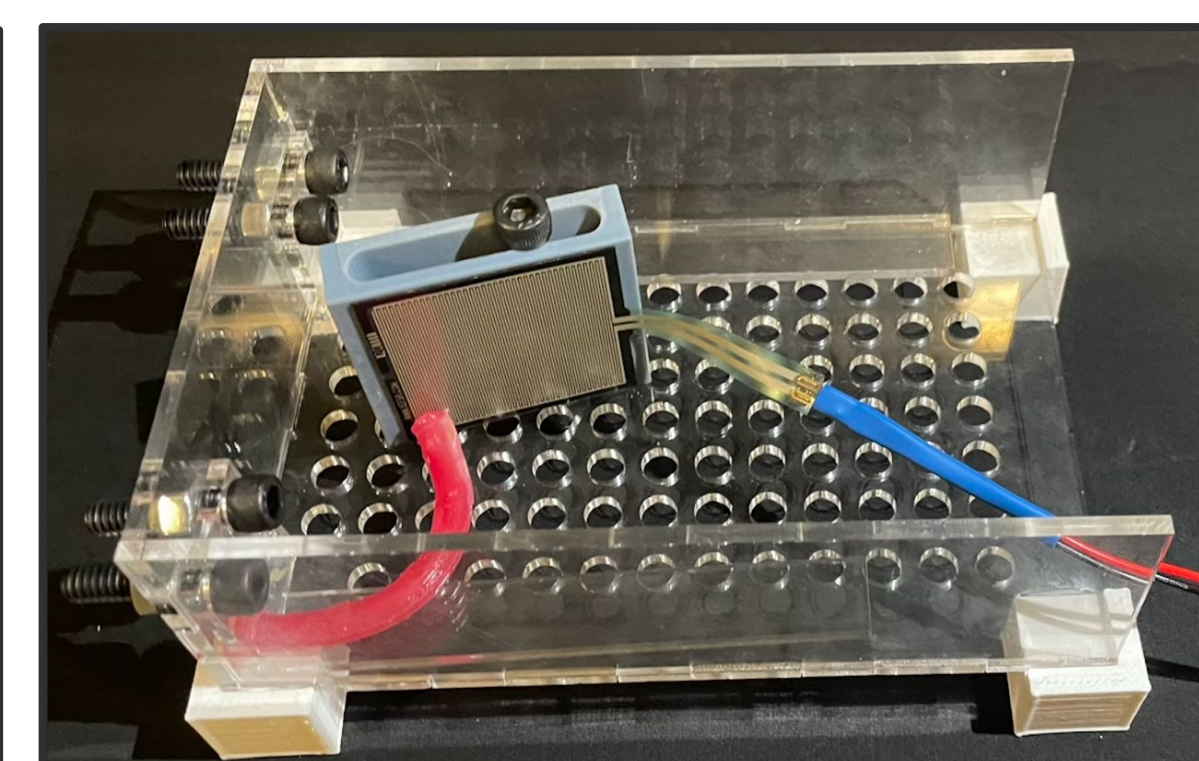

Force Test Fixture

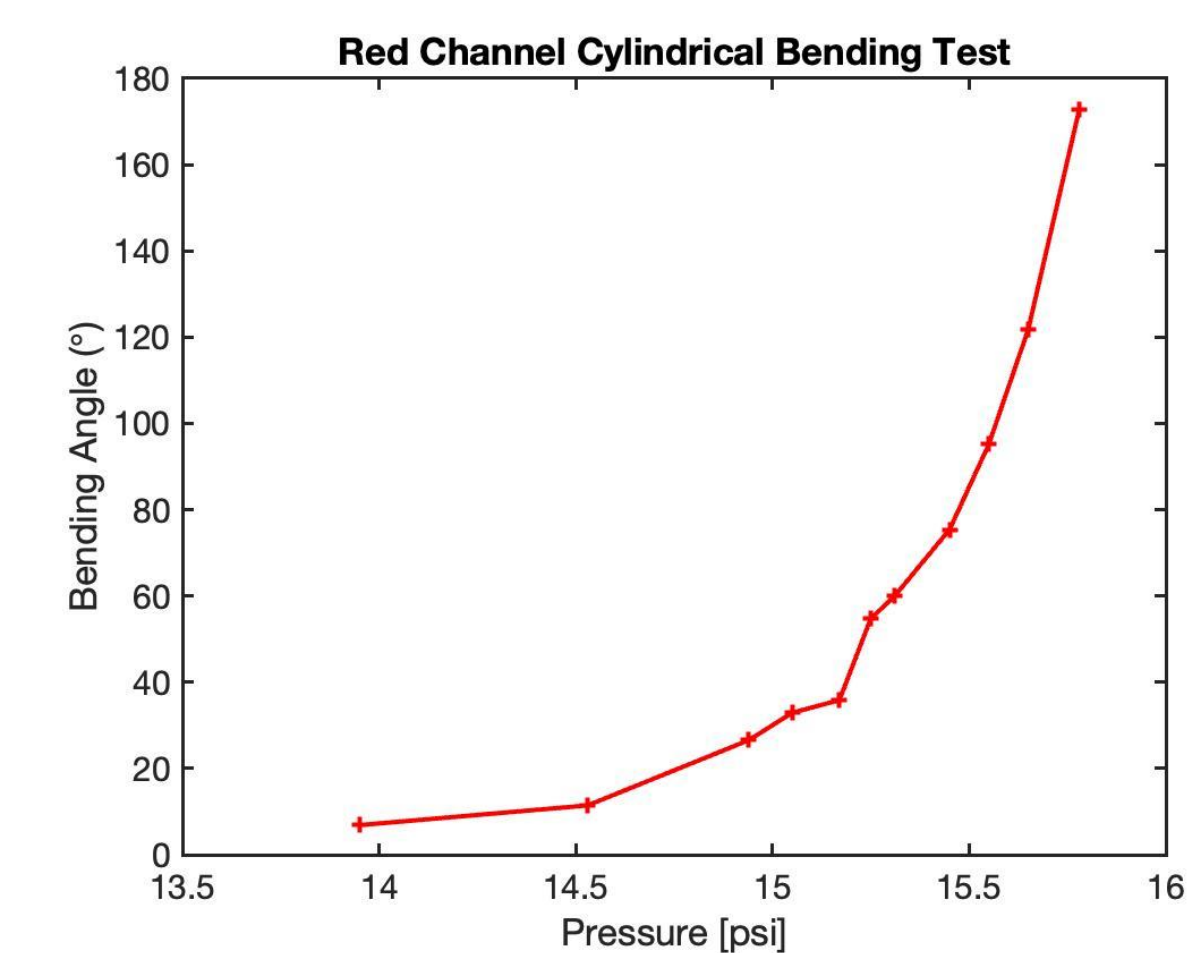
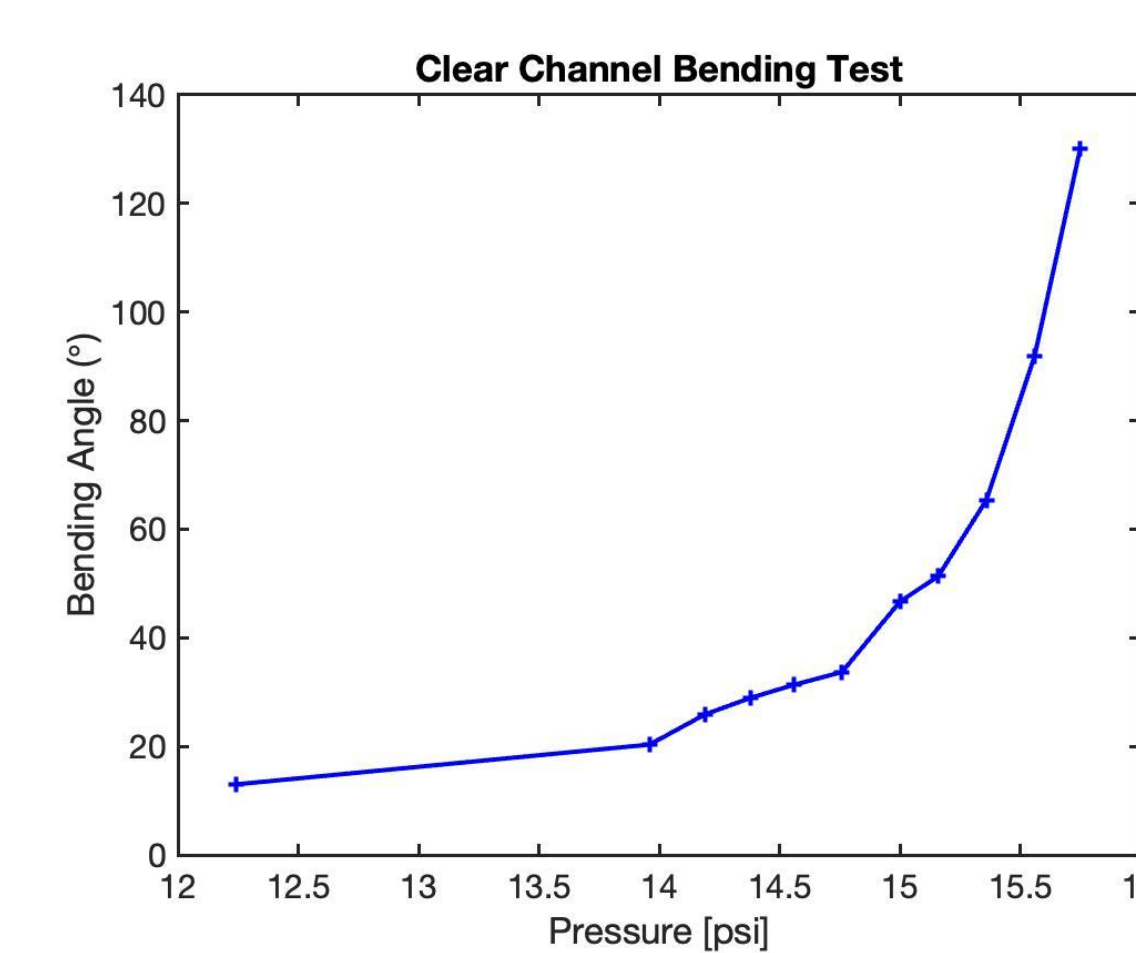

Bending Test Results

- Pressure commands were manually sent to induce actuation at designated increments
- Snapshots of bending was collected and angles processed in MATLAB's imaging software

6 Future Work

- Reducing outer diameter from 6mm to ~2mm
- Manufacturing of mold for use in injection molding processes
- Analysis of materials and impacts of material properties
- Refining of design and eliminating discrepancies in manufacturing process
- Implement more sophisticated feedback algorithm on three channel robot to reject disturbances

Acknowledgements

Thank you to Daria Kotys-Schwartz, Julie Steinbrenner, Drew Wilson, Jing Zhao, Robert Wham, John Komp, Shalom Ruben, Patrick Maguire, Derek Westmoreland